

User's Manual

Cera Caliper Checker

MANUAL NO. 4700

Mitutoyo

CONTENTS

1. OVERVIEW	11
2. AVAILABLE MODELS	11
3. COMPONENTS	11
4. FUNCTIONS	12
5. SPECIFICATIONS	12
6. OPERATION	13
6.1 Method of Accuracy Checks	13
6.2 Reference Dimensions	14
7. STANDARD ACCESSORIES	15
8. OPTIONAL ACCESSORIES	15
9. PRECAUTIONS ON HANDLING	15
SERVICE NETWORK	17

1. OVERVIEW

The Mitutoyo Cera Caliper Checker is a reference standard designed to check the accuracy of calipers and height gages. It has employed ceramic (ZrO₂) reference blocks and base block in order to enhance the abrasion resistance of the measuring surfaces. This allows the Cera Caliper Checker to maintain its high measuring accuracy for long period of time.

In order to obtain the best possible performance and longest service life of your Cera Caliper Checker, read this user's manual carefully prior to operation.

2. AVAILABLE MODELS

Code No.	Name	Measuring range
515-555	CC300C	20 – 300mm
515-556	CC600C	20 – 600mm
515-565	CC12"C	1 – 12"

3. COMPONENTS

The Cera Caliper Checker consists of the following components as shown below.

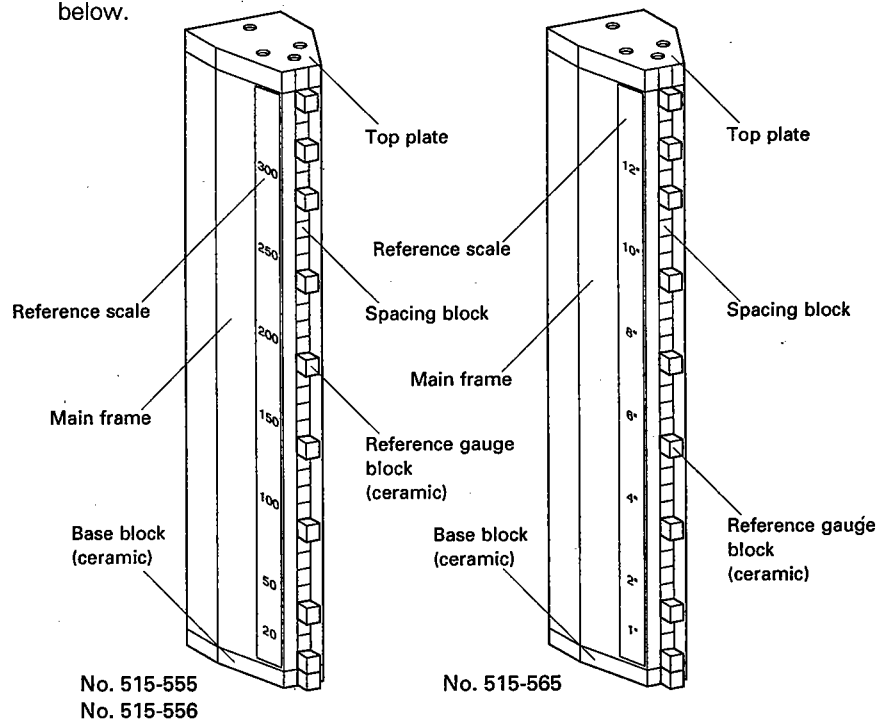

Fig. 1

4. FUNCTIONS

Code No.	515-555	515-556	515-565
Item			
Name	Cera Caliper Checker CC300C	Cera Caliper Checker CC600C	Cera Caliper Checker CC12°C
Measuring range			
Outside measurement	20, 50, 100, 150, 200, 250, 300, 330, 360	20, 50, 100, 150, 200, 300, 400, 500, 550, 600, 630, 670	1", 2", 4", 6", 8", 10", 12"
Inside measurement	20, 50, 100, 150, 200, 250, 300, 330	20, 50, 100, 150, 250, 350, 450, 500, 550, 600, 630	1", 2", 4", 6", 8", 10", 12"
Height measurement	20, 50, 100, 150, 200, 250, 300, 330, 360	20, 50, 100, 150, 200, 300, 400, 500, 550, 600, 630, 670	1", 2", 4", 6", 8", 10", 12"
Mass	Approx. 4kg	Approx. 8.5kg	8.8lbs.

5. SPECIFICATIONS

Code No.	515-555	515-556	515-565
Item			
Accuracy of block pitch	$\pm 0.005\text{mm}$	$\pm 0.005\text{mm}$ (for a length 300mm or less) $\pm 0.007\text{mm}$ (for a length more than 300mm)	$\pm 0.0002^*$
Parallelism of block surfaces	0.002mm	0.002mm (for a length 300mm, or less) 0.004mm (for a length more than 300mm)	0.00008*
Surface roughness of measuring surfaces	0.08S	0.08S	0.08S
Hardness of gauge blocks	HV1350	HV1350	HV1350

Note) The above described figures are based on the industrial standard temperature of 20°C.

6. OPERATION

This instrument is designed to check the accuracy of calipers and height gages. In each type of use, please note the following points.

6.1 Method of Accuracy Checks

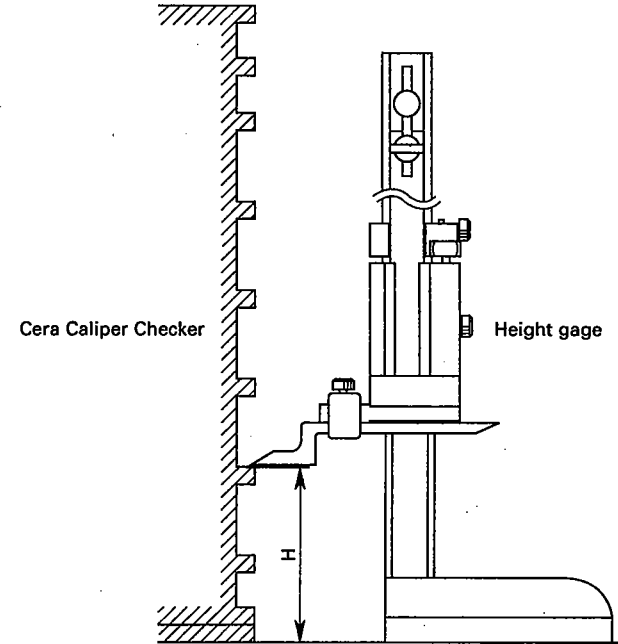

Fig. 2 Checking the height gage accuracy

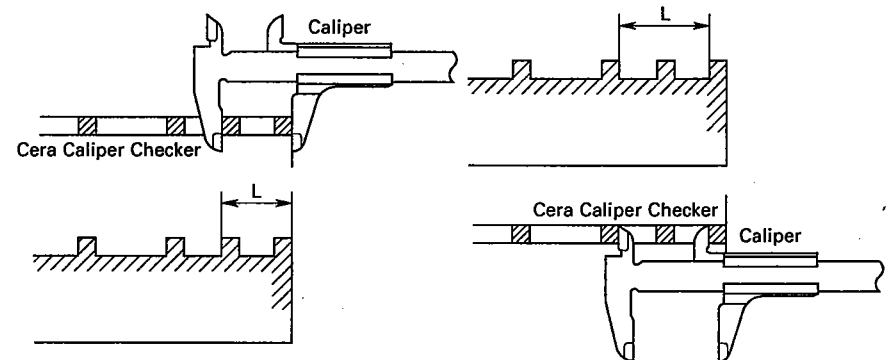

Fig. 3 Checking the caliper (outside-measurement accuracy)

Fig. 4 Checking the caliper (inside-measurement accuracy)

6.2 Reference Dimensions

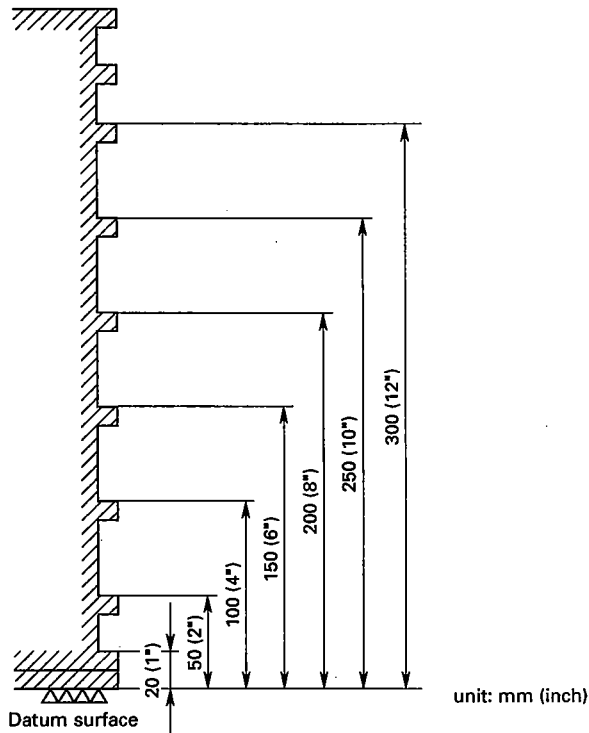

Fig. 5 Reference dimensions for checking the height gage or caliper (outside-measurement accuracy)

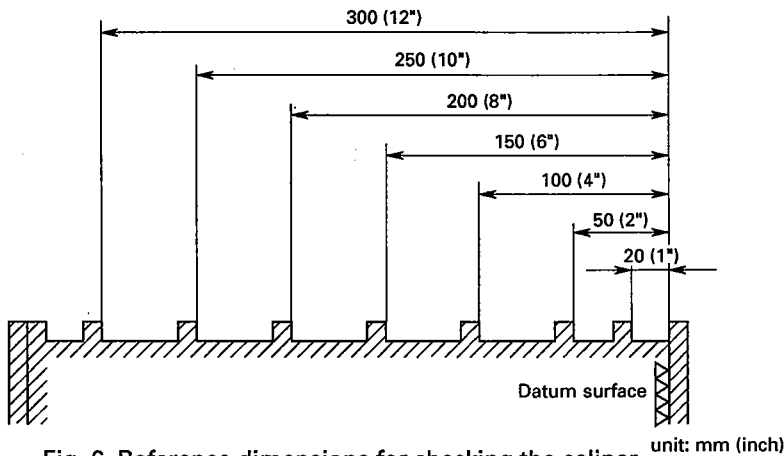

Fig. 6 Reference dimensions for checking the caliper (inside-measurement accuracy)

7. STANDARD ACCESSORIES

- 1) Vinyl cover
- 2) User's Manual (No. 4700)
- 3) Inspection certificate

8. OPTIONAL ACCESSORIES

Wooden box No. 515-555, No. 515-565 Order No. 602162
 No. 515-556 Order No. 602164

9. PRECAUTIONS ON HANDLING

- 1) Handle with care so that it is not subjected to impact when you carry it or place it on the surface plate.
- 2) Before starting operation, wipe off dust from the measuring surfaces of the gauge blocks with a clean cotton cloth or gauze. After use, lightly apply high-quality anti-corrosive oil to the spacing blocks.
- 3) Before you use the Cera Caliper Checker on a surface plate, wipe the surface plate clean.
- 4) As the gauge blocks and spacing blocks have been precisely assembled and adjusted at the factory, never disassemble the Cera Caliper Checker for re-adjustment.
 Should a malfunction occur on the Cera Caliper Checker, leave it as-is and contact your dealer or the nearest Mitutoyo sales office.